

ACCESSORI DI COLLEGAMENTO ED INTERVENTO

VALVOLE
DN 60 - 300



23/03/2021

INCGIFLAGSSPM00

QUICK GS – Versione semplice DN60-300

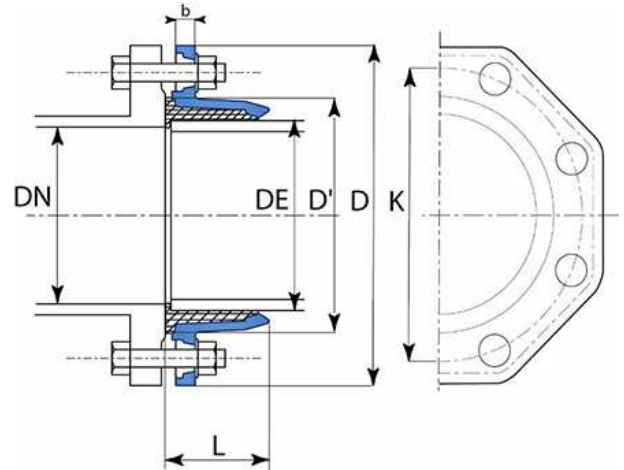

DN flangia	Ø DE	L	D	D'	b	K	Peso	Codici
mm	mm	mm	mm	mm	mm	mm	kg	
60-65	77	51	185	110	16	145	1.80	MAA60CACH
80	98	56	200	134.5	16	160	2.25	MAA80CACH
100	118	63	220	156	16	180	2.65	MAB10CACH
125	144	70	250	183	16	210	3.65	MAB12CACH
150	170	76	285	210	16	240	4.60	MAB15CACH
200*	222	90	340	265	17	295	7.15	MAB20CACH
250*	274	108	400	322	19	350 (PN10) - 355 (PN16)	10.90	MAB25CACH
300*	326	117	455	373	20.5	400 (PN10) - 410 (PN16)	13.80	MAB30CACH

* DN200-250-300: flangia multiferata ISO PN10 and ISO PN16

Materiali e rivestimenti

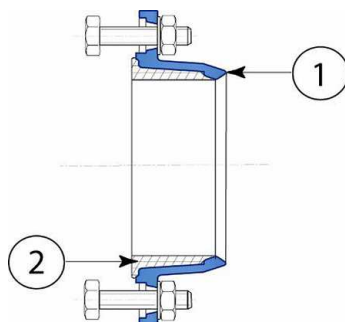

1- Contro-flangia: Ghisa sferoidale rivestita con polveri epossidiche di spessore minimo 250 µm in conformità alla EN 14901

2- Guarnizione di tenuta: EPDM